



Low Exergy Solar thermal supply for community based energy

Drake Landing as a working example

Ken Church P Eng
CanmetENERGY
Natural Resources Canada`



Credits to:

Drake Landing Solar Community

Natural Resources Canada – Doug Mclenahan

SAIC – Bill Wong

ATCO Gas

and many others....



Natural Resources
Canada

Ressources naturelles
Canada

Canada

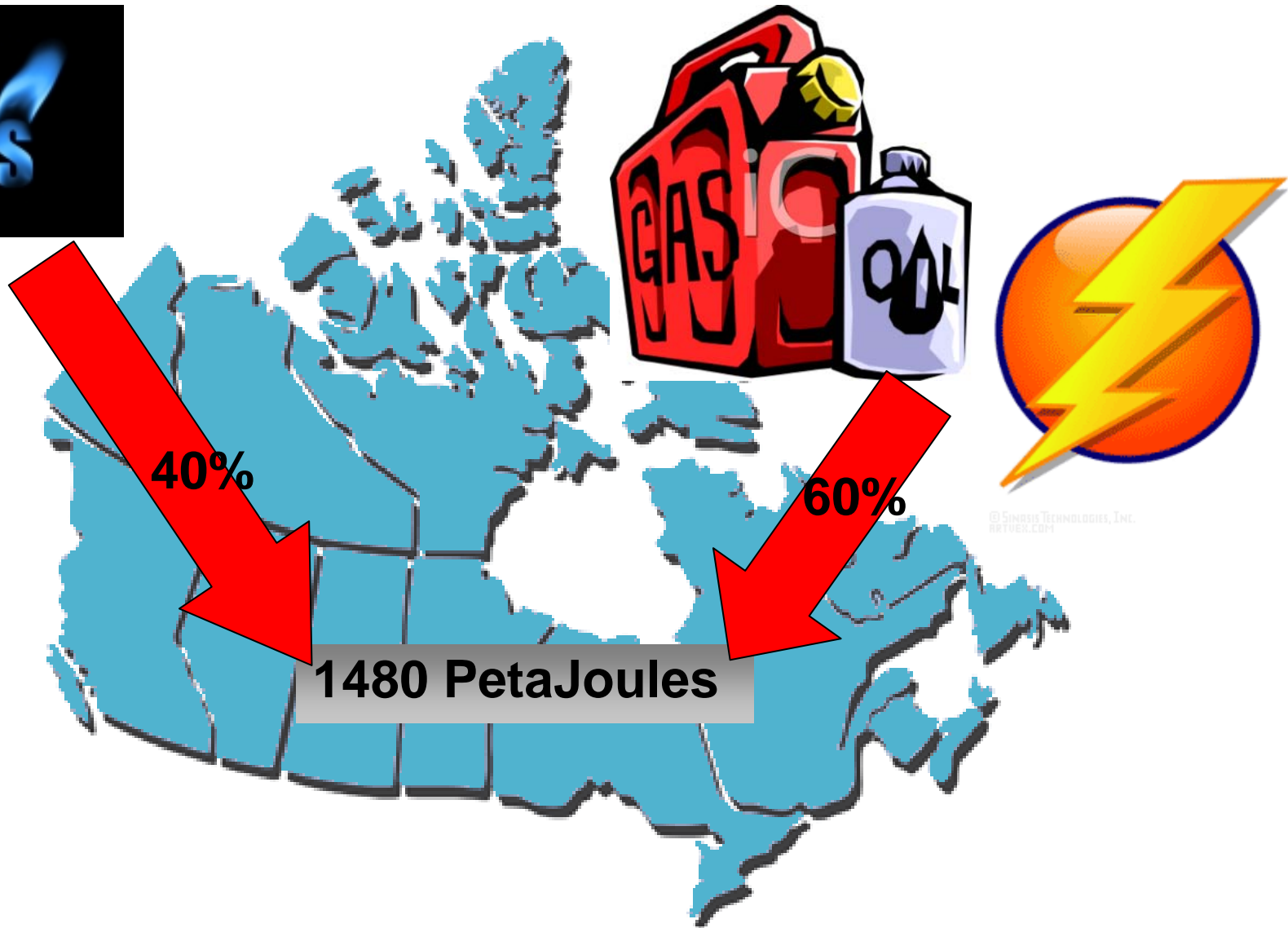

Canadian Energy Streams

CanmetENERGY

Leadership in ecoInnovation



Natural Resources
Canada

Ressources naturelles
Canada

Canada

Canadian Electrical Supply

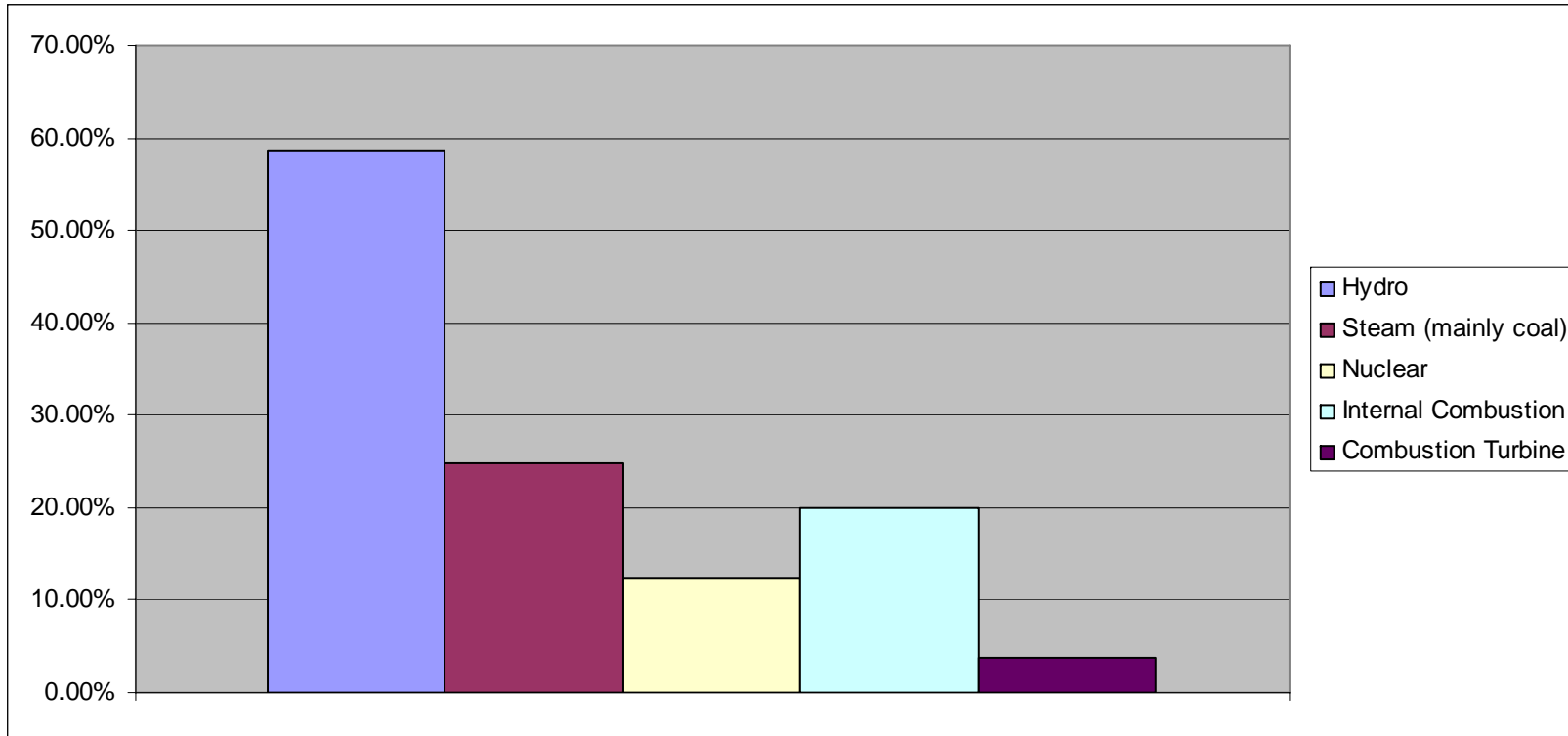

CanmetENERGY

Leadership in ecoInnovation



Natural Resources
Canada

Ressources naturelles
Canada

Canada

Canadian Mentality

We have the resources

Use them

Wisely

But

Don't forget

Resources mean jobs.....

CanmetENERGY

Leadership in ecoInnovation



Natural Resources
Canada

Ressources naturelles
Canada

Canada

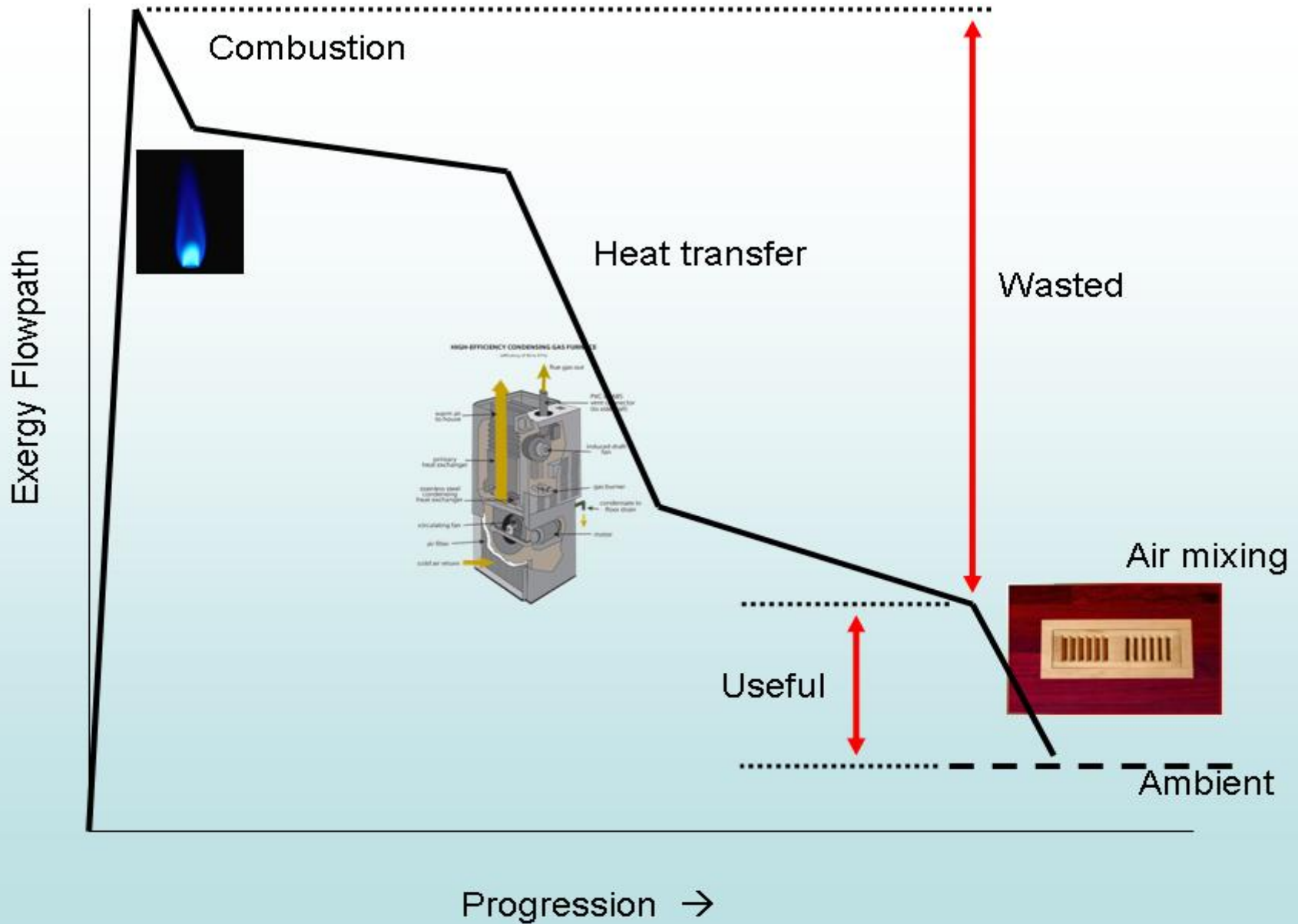

Typical Exergy Flow



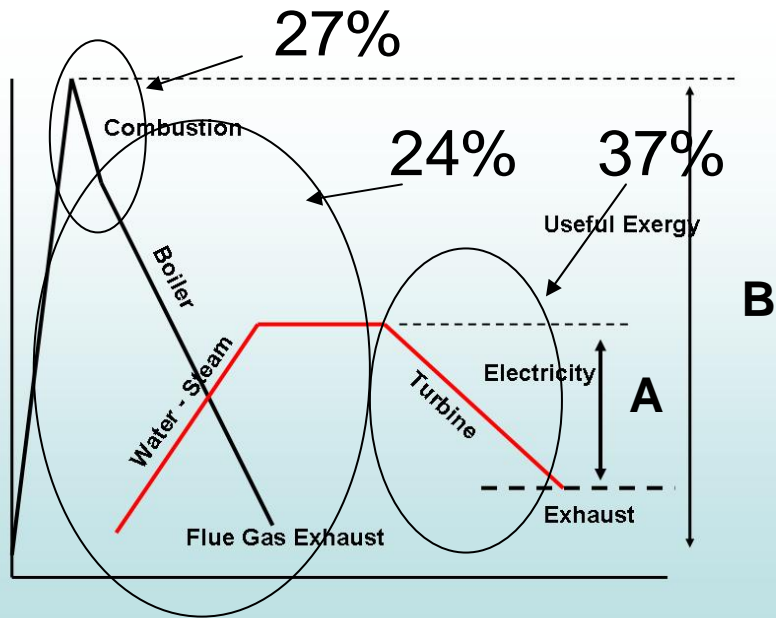

Steam Turbine

$$\text{Efficiency} = \frac{\sum B}{A}$$

$$= B/A$$

Gas Turbine

$$\text{Efficiency} = \frac{\sum B}{A}$$

$$= (B1+B2)/A$$

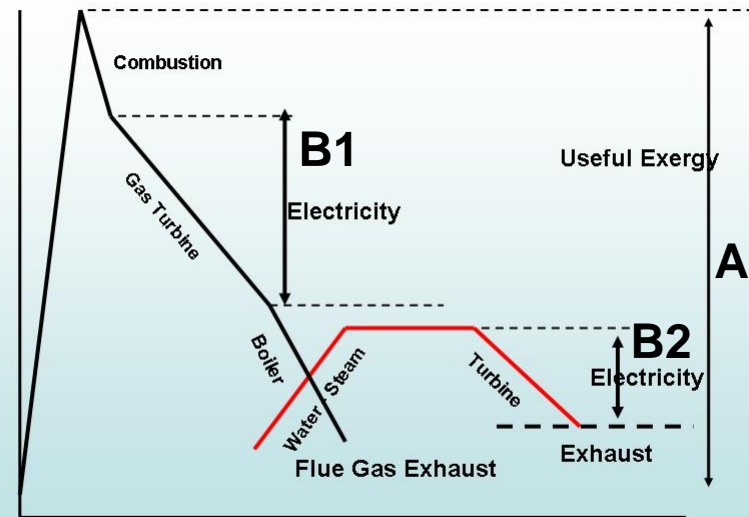

CanmetENERGY

Leadership in ecoInnovation



Natural Resources
Canada

Ressources naturelles
Canada

Canada



Drake Landing Solar Community

CanmetENERGY

Leadership in ecoInnovation



Natural Resources
Canada

Ressources naturelles
Canada

Canada

Okotoks Housing and Panels



CanmetENERGY

Leadership in ecoInnovation



Natural Resources
Canada

Ressources naturelles
Canada

Canada

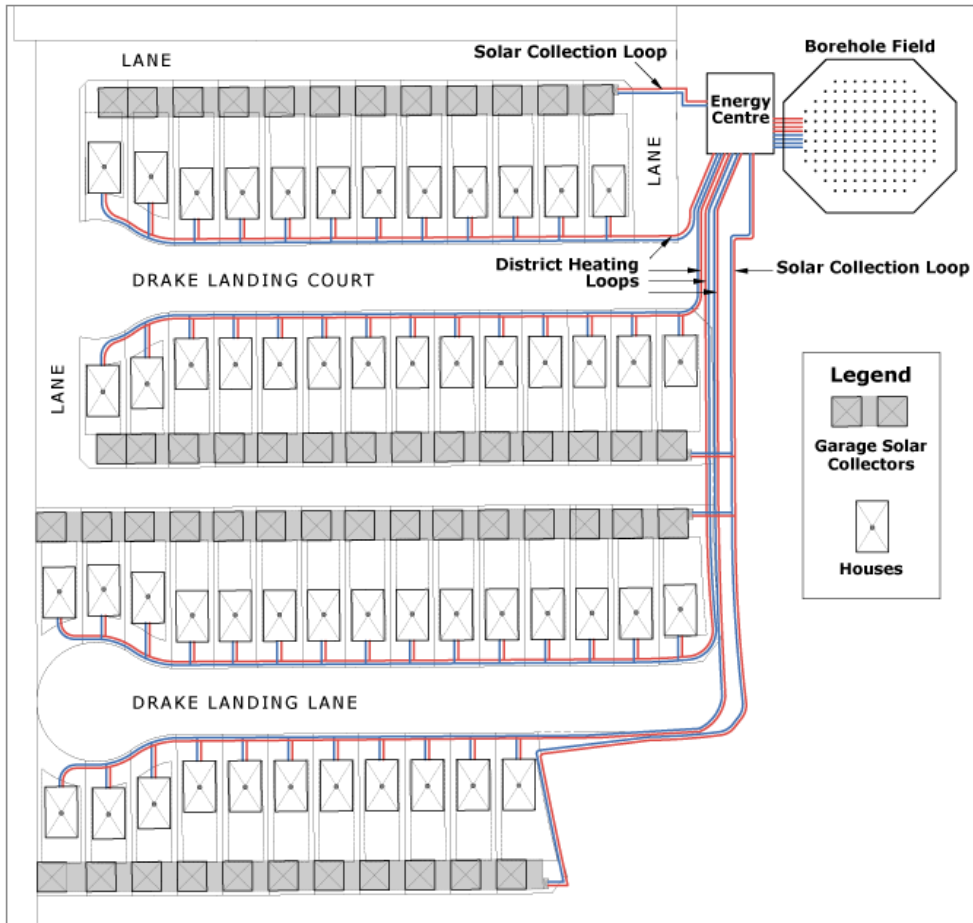

Collection and Distribution piping

Garage mounted solar collectors



CanmetENERGY

Leadership in ecoInnovation



Natural Resources
Canada

Ressources naturelles
Canada

Canada

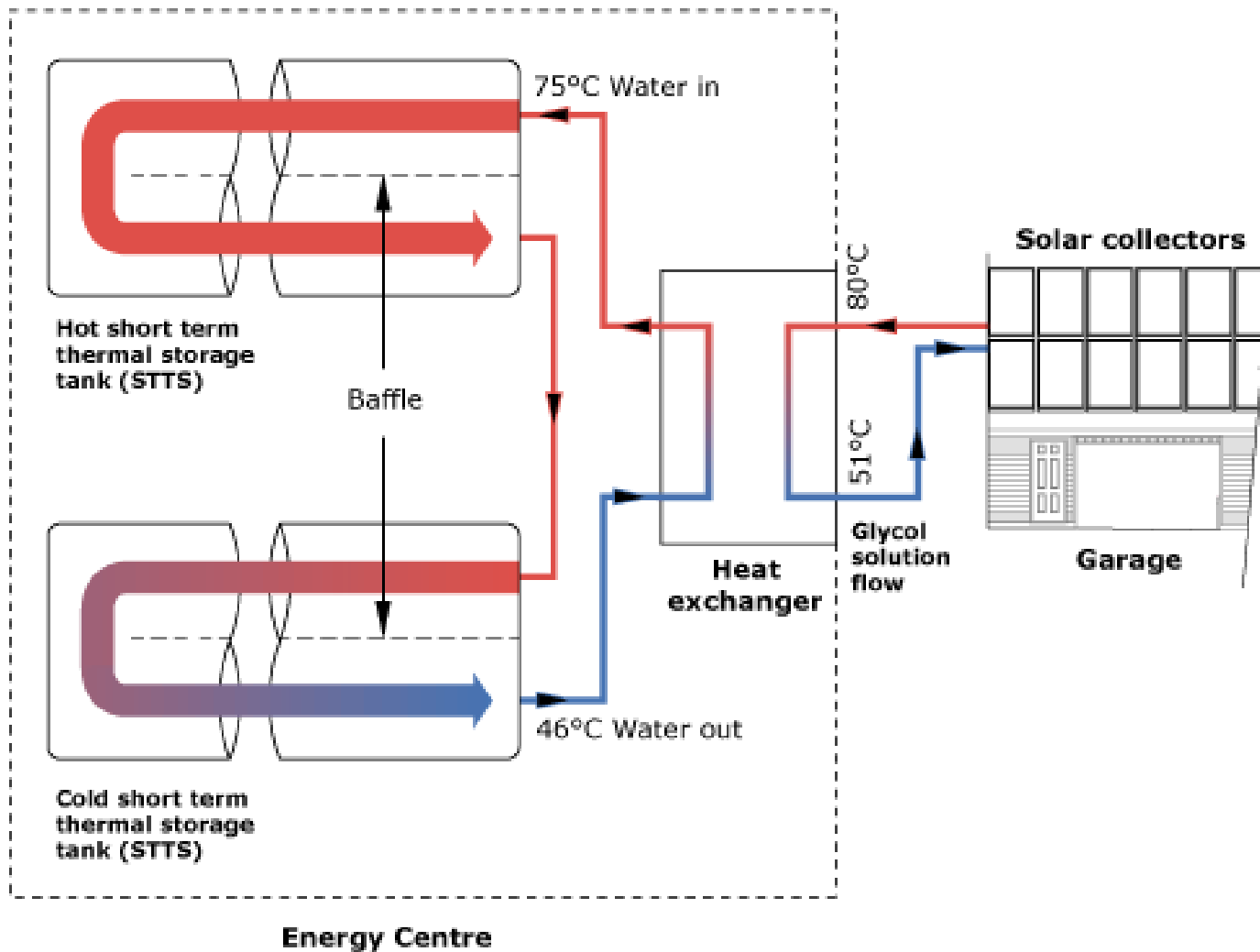

CanmetENERGY

Leadership in ecoInnovation



Natural Resources
Canada

Ressources naturelles
Canada

Canada

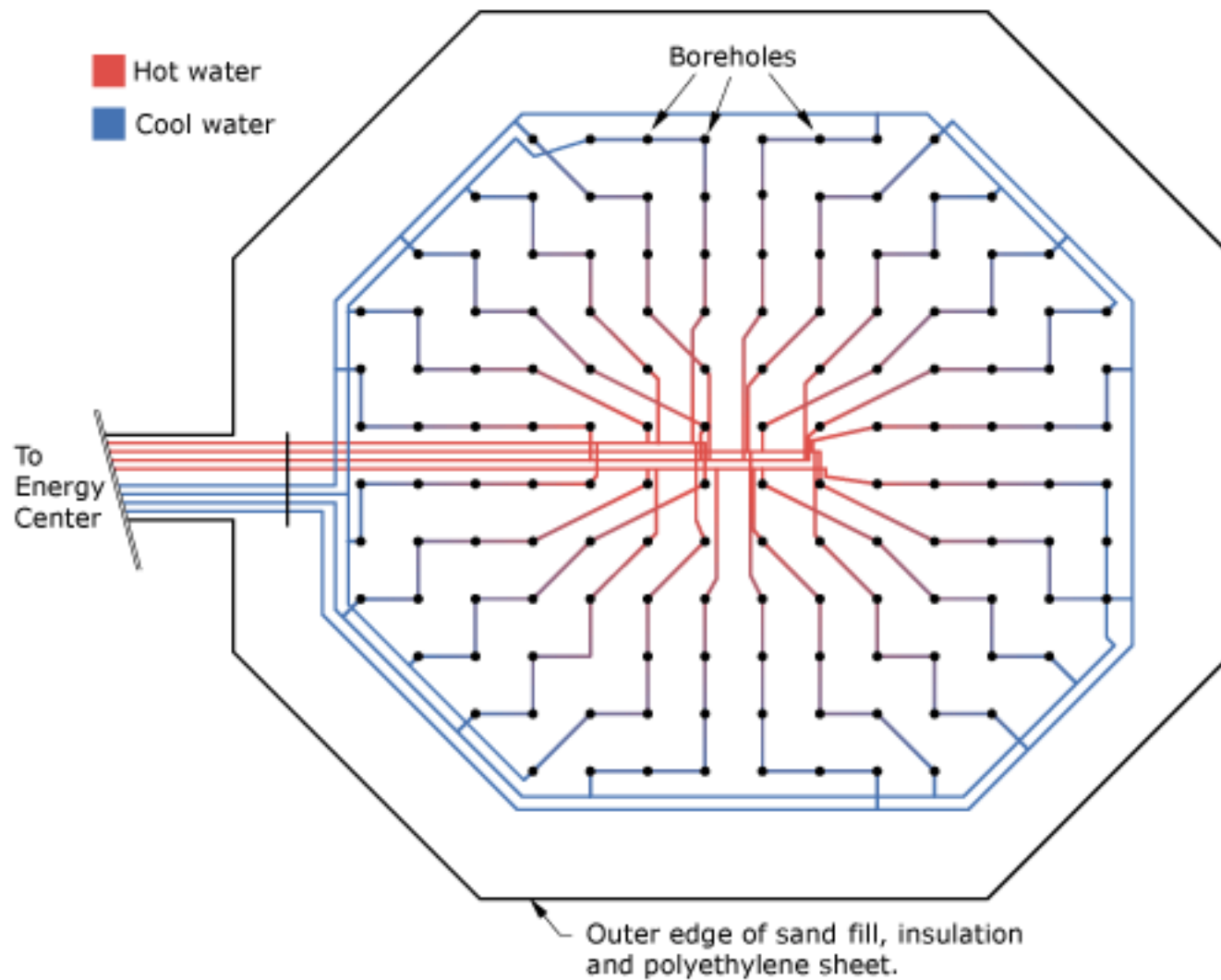

CanmetENERGY

Leadership in ecoInnovation



Natural Resources
Canada

Ressources naturelles
Canada

Canada

Borehole Thermal Energy Storage

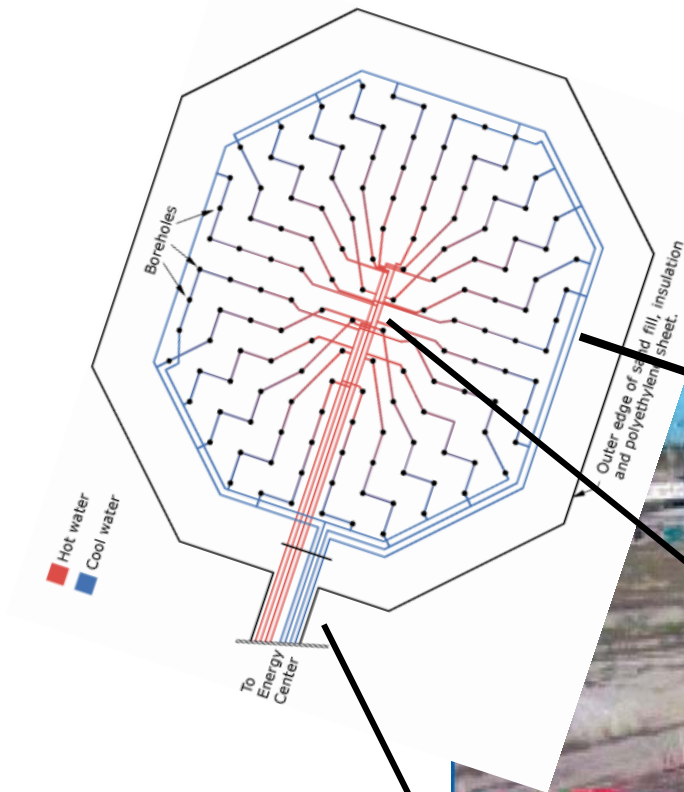

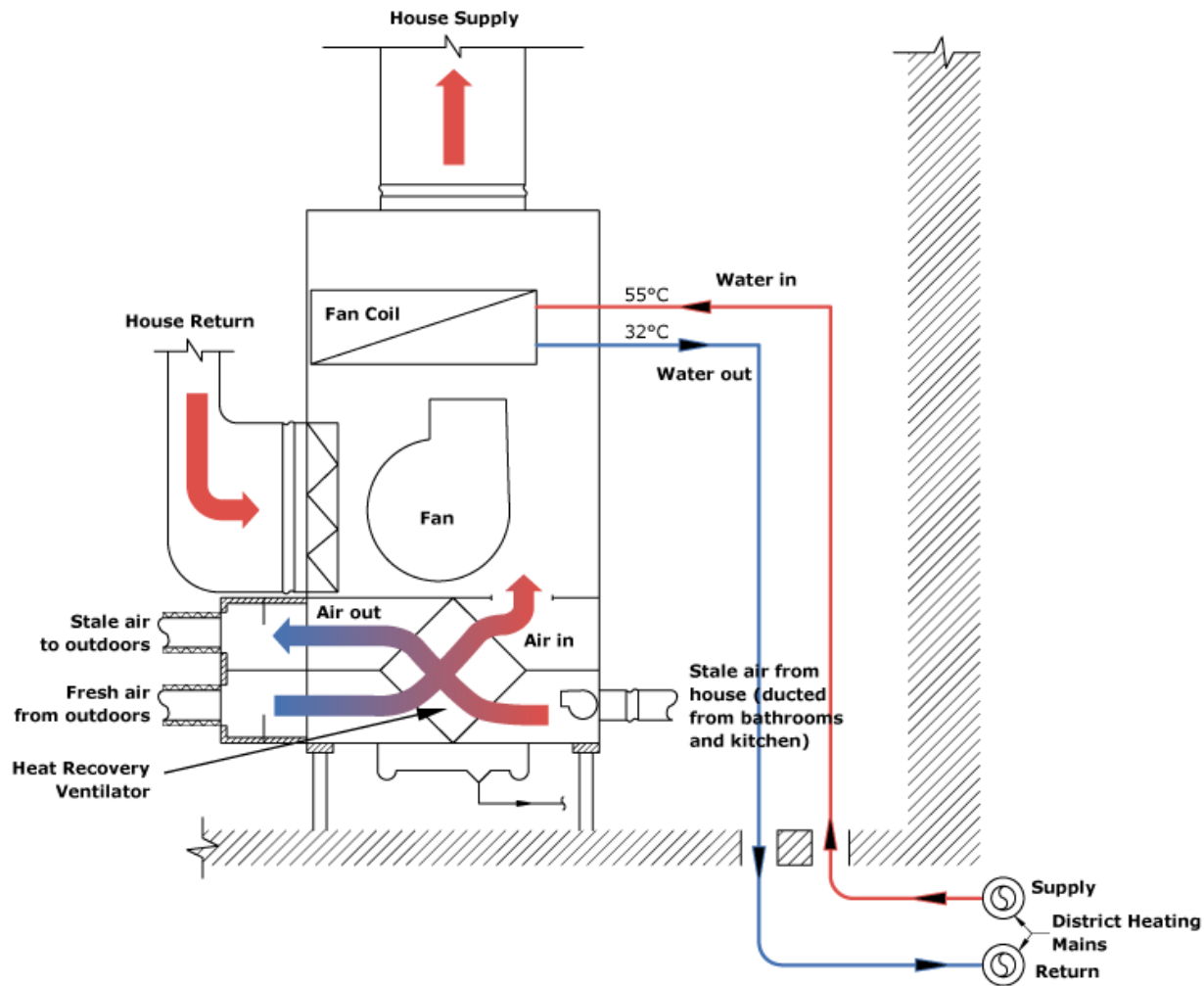

CanmetENERGY

Leadership in ecoInnovation



Natural Resources
Canada

Ressources naturelles
Canada

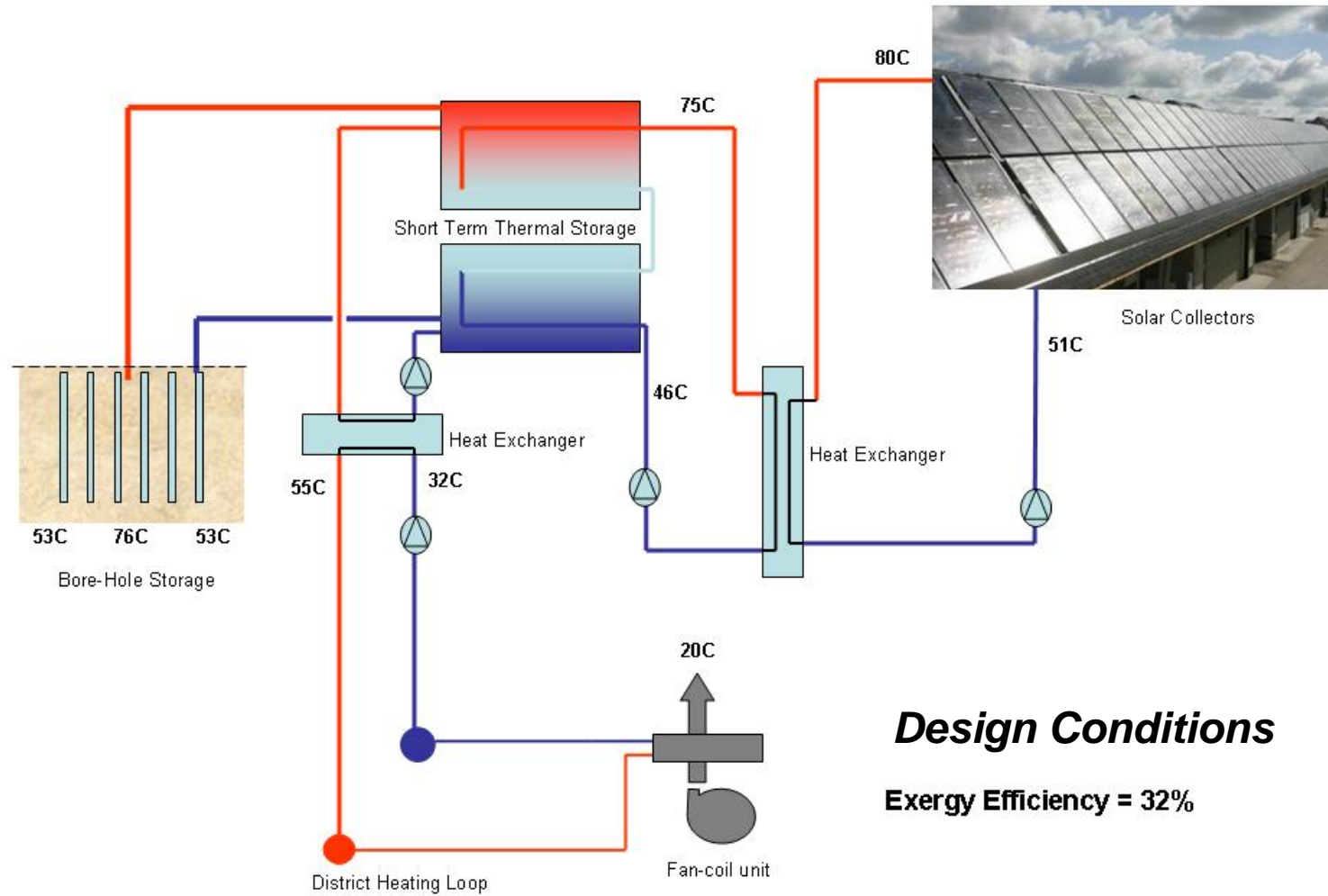

Design Conditions
Exergy Efficiency = 32%

CanmetENERGY

Leadership in ecoInnovation



Natural Resources
Canada

Ressources naturelles
Canada

Canada

Sources of Confusion

- Source Temperature
- Ambient Temperature
- Efficiency

CanmetENERGY

Leadership in ecoInnovation



Natural Resources
Canada

Ressources naturelles
Canada

Canada

Solar Fraction (%)

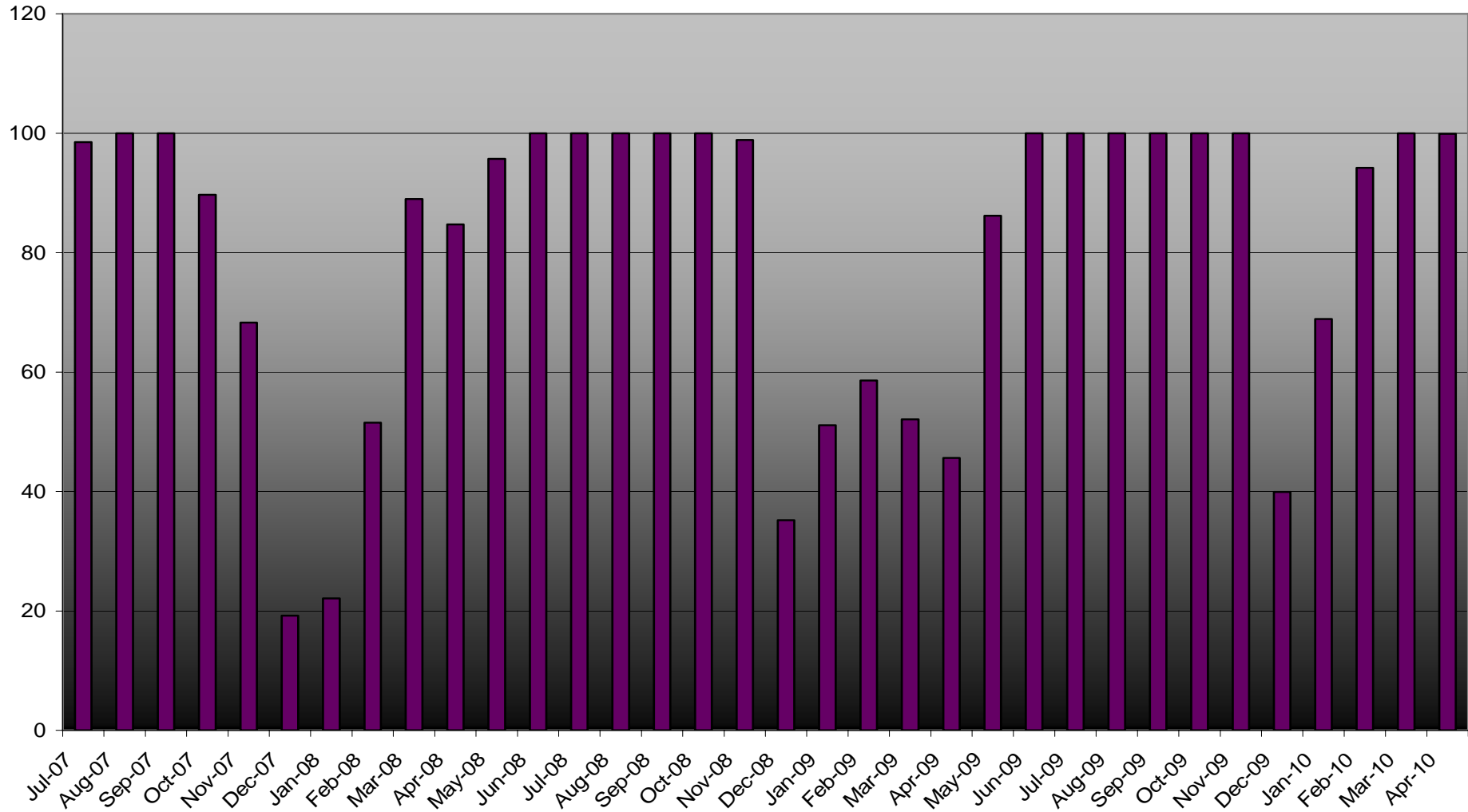

CanmetENERGY

Leadership in ecoInnovation



Natural Resources
Canada

Ressources naturelles
Canada

Canada

Solar & Gas Heating

Gas Supplement

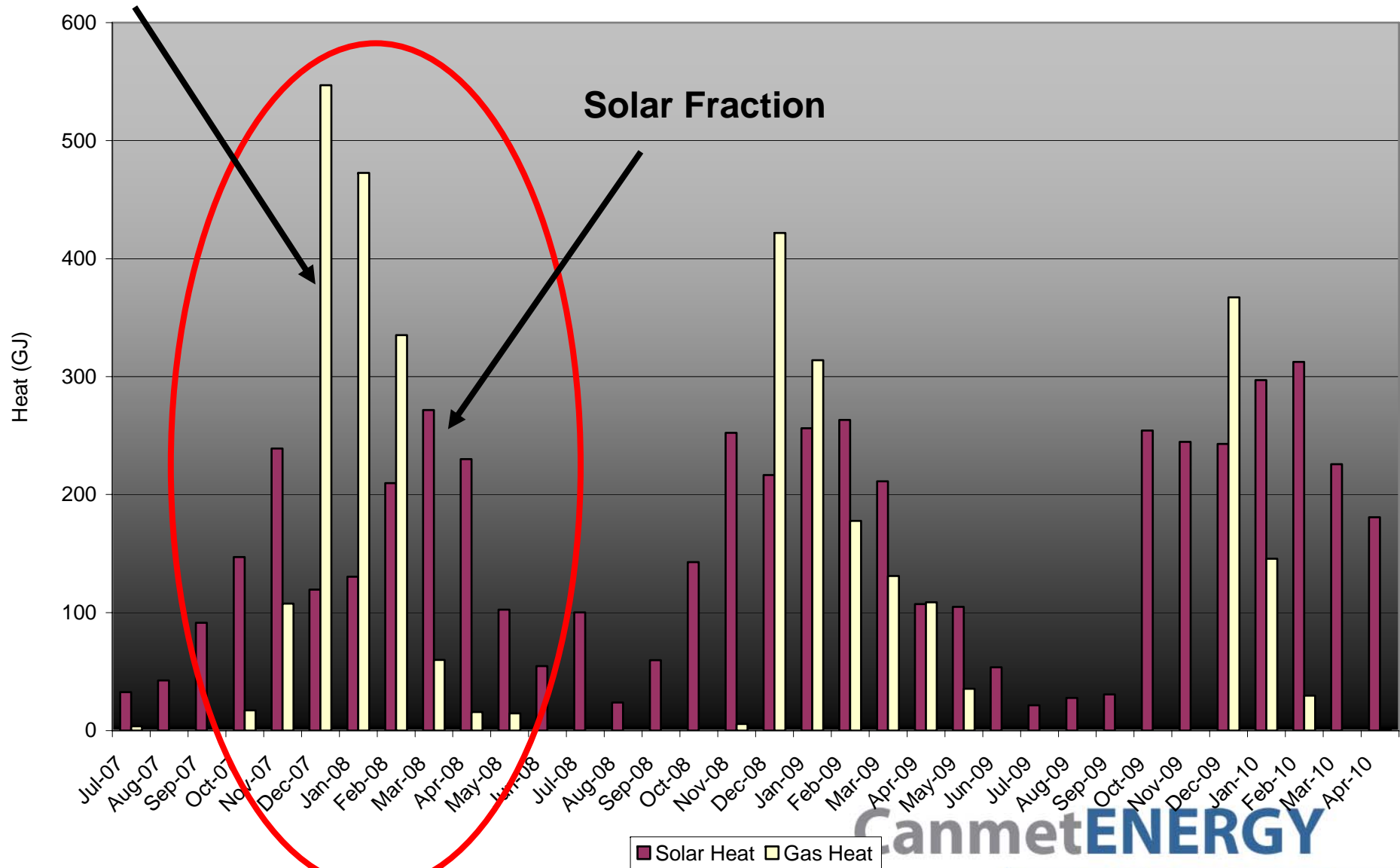

CanmetENERGY

Leadership in ecoInnovation

Heating Program Changes

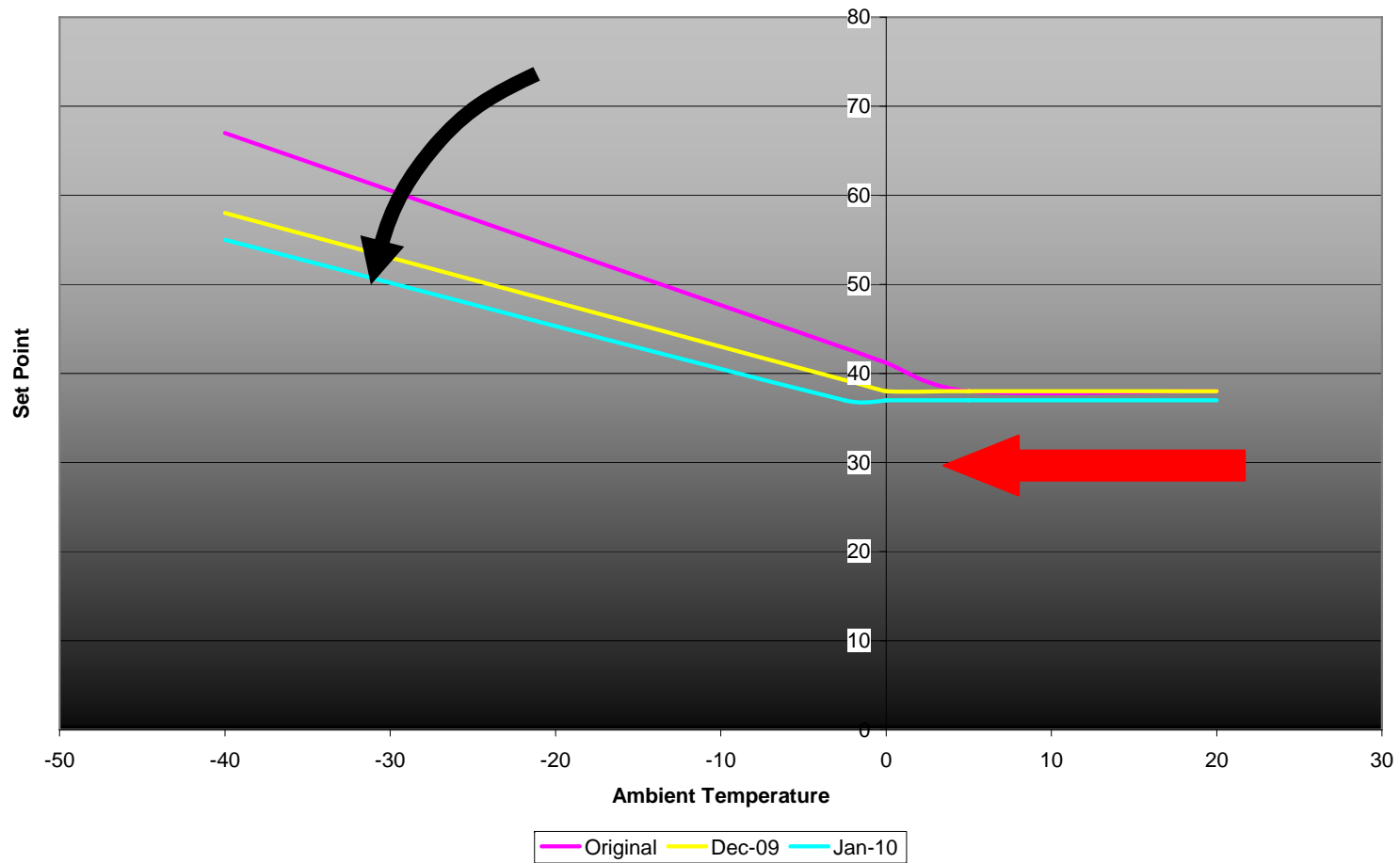

CanmetENERGY

Leadership in ecoInnovation



Natural Resources
Canada

Ressources naturelles
Canada

Canada

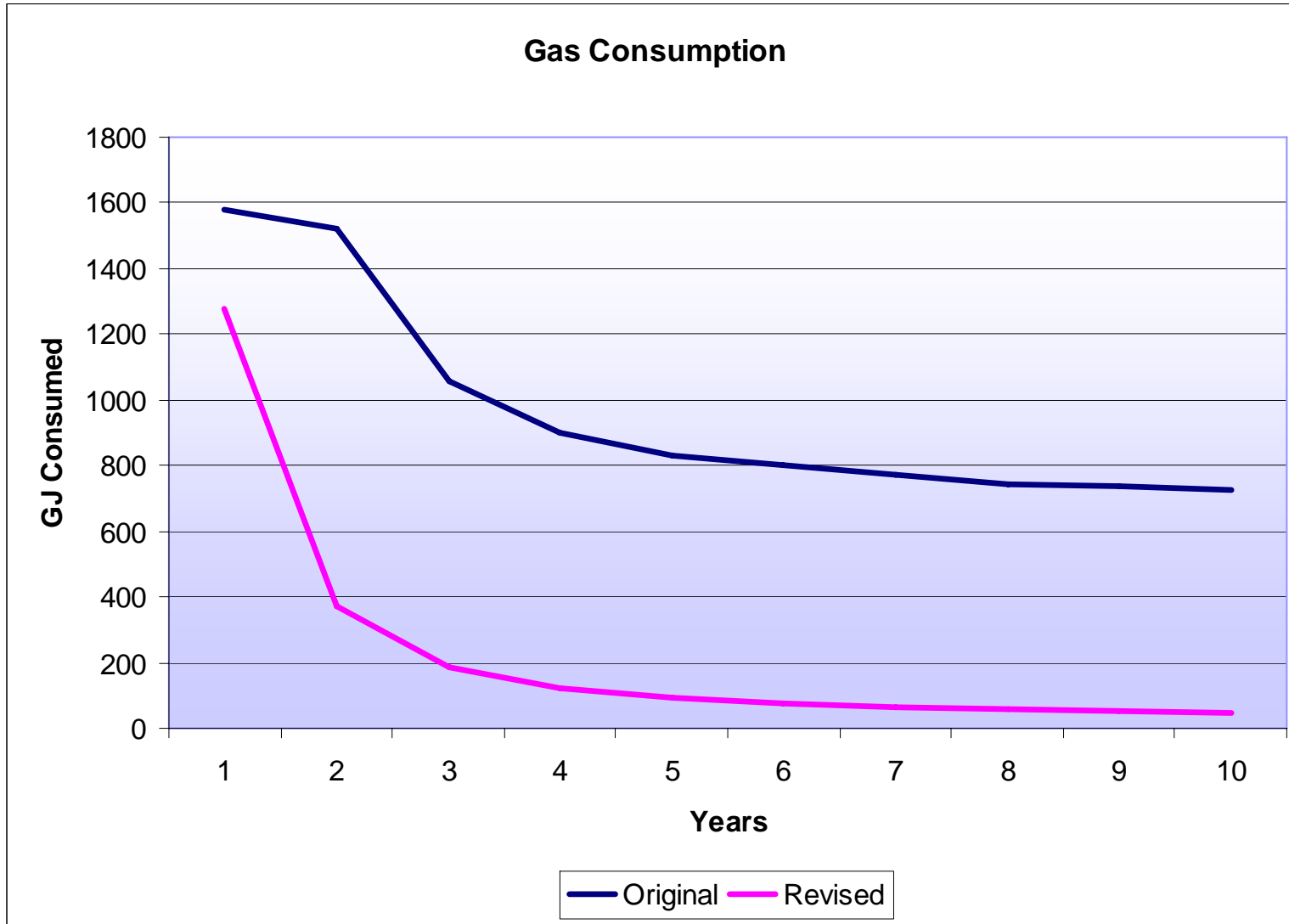

Net Gas Savings = \$10,668 (€8000) over 10 years

CanmetENERGY

Leadership in ecoInnovation



Natural Resources
Canada

Ressources naturelles
Canada

Canada

Conclusions

- 1 Low Exergy or Low Exergy Losses?***
- 2 Parameters of Exergy must be defined***
- 3 Exergy identifies losses not efficiency***
- 4 Exergy can be used to eliminate fossil fuels***
- 5 Implementation of exergy requires reconfiguration of buildings***

<http://www.dlsc.ca/>

CanmetENERGY

Leadership in ecoInnovation



Natural Resources
Canada

Ressources naturelles
Canada

Canada